



# ANT-D5G-15

15dBi 室外指向型天線

## 天線規格

頻率範圍	5150 - 5875 MHz
天線增益值	15.0±1 dBi
Polarization	Linear, ±45°
水平角度	60° @ 3dB / 90° @ 6dB
垂直角度	6° @ 3dB / 8° @ 6dB
前後比	-20dB (Max.)
輸入阻抗	50 Ohm
Cable	N/A
連接頭	N jack x 2
Power Handling	6 W (cw)
Lightning Protection	DC ground
最大風速承受	216 km/hr
溫度	-40°C to +80°C
濕度	95% @ 55°C
重量	1.06kg 1.54 kg (Include mounting kit)
體積	540 x 116 x 39 mm
防水防護等級	IPX5
安裝支架配件組	抱桿 & 壁掛安裝
Side Lobe Level	-6 dB ( Max.)
Isolation	20 dB (Min.)
Radome color	Warm gray 1C
Radome materia	ASA, UV resistant



Port1

Port2

H-plane Co-polarization Pattern

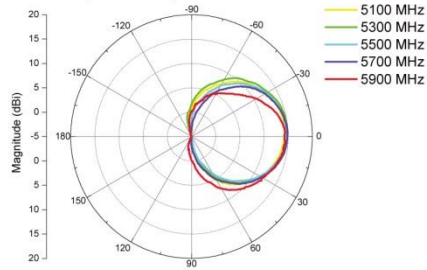

H-plane Co-polarization Pattern

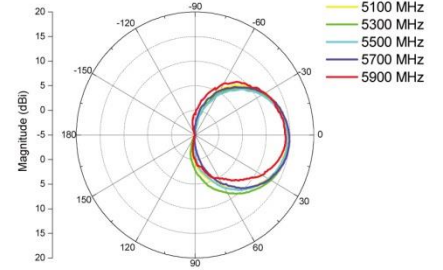

V-plane Co-polarization Pattern

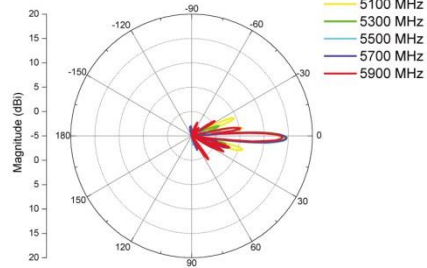

V-plane Co-polarization Pattern

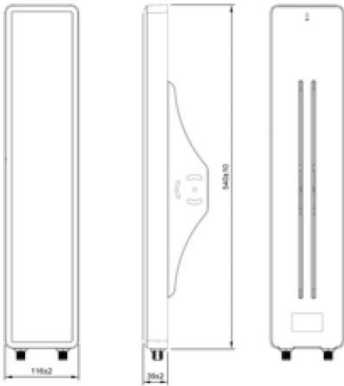
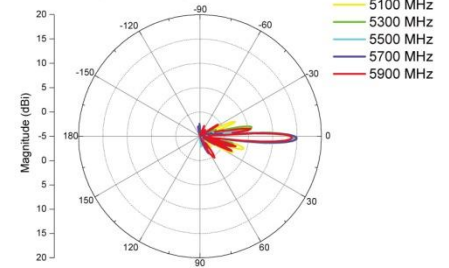

# Radiation Pattern

Port1

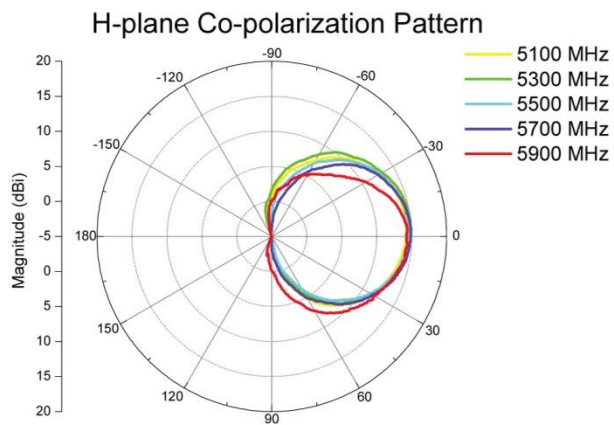

Port2

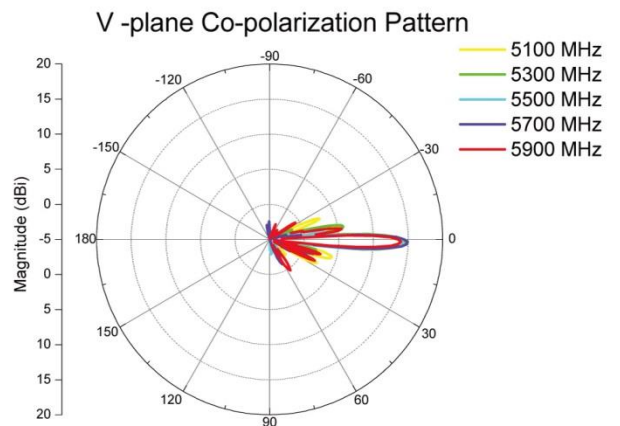
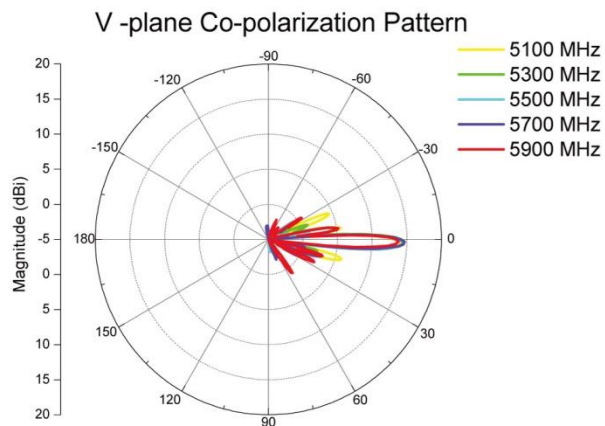
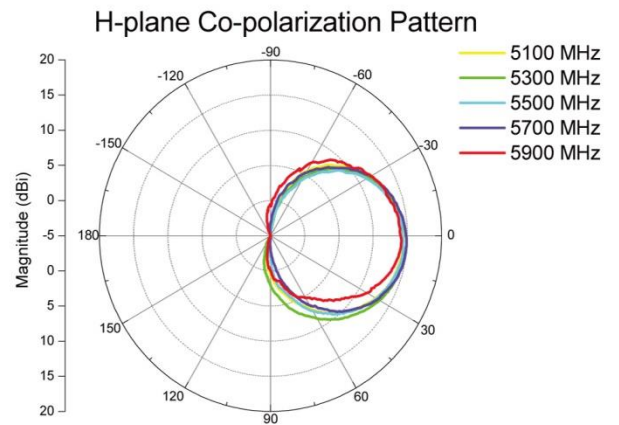

# Product Drawing

GENERAL TOLERANCE RANGE	
□ INJECTION(射出件)	X=±0.5 X.X=±0.3 X.XX=±0.2
■ ASSEMBLY(組合作件)	X=±5 X.X=±2 X.XX=±1
ANGLES: X=±2°	
UNIT : MM	

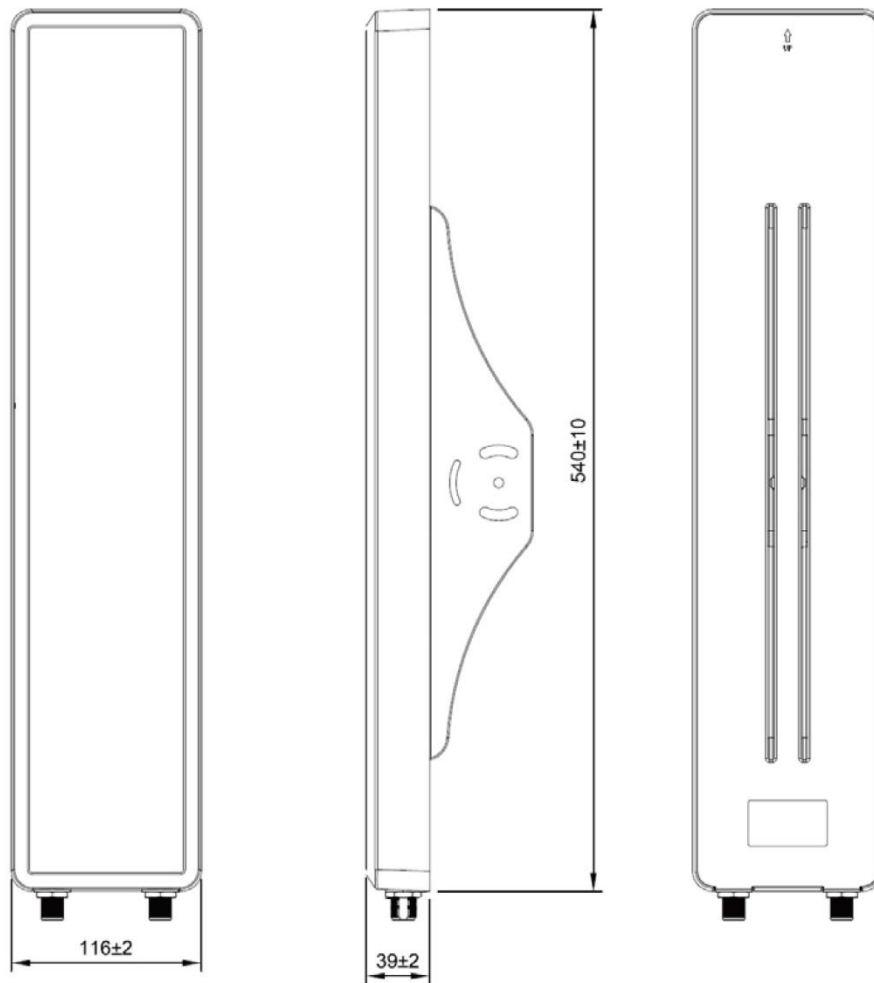

# Mounting Configuration

- ① Antenna body - 1 pc
- ② M6 washer - 4 pcs
- ③ M6 S/W - 2 pcs
- ④ M6 nut - 2 pcs
- ⑤ M6-40 bolt - 2 pcs
- ⑥ Pole bracket - 1 pcs
- ⑦ 3" Pole lock frame - 1 pcs

- ⑧ M8 washer - 4 pcs
- ⑨ M8 S/W - 4 pcs
- ⑩ M8 nut - 2 pcs
- ⑪ M8-110 bolt - 2 pcs
- ⑫ Pole(Diameter :1.5"~3")
- ⑬ Anchor - 4 pcs
- ⑭ Screw - 4 pcs
- ⑮ Wall

## 1.Pole Mounting

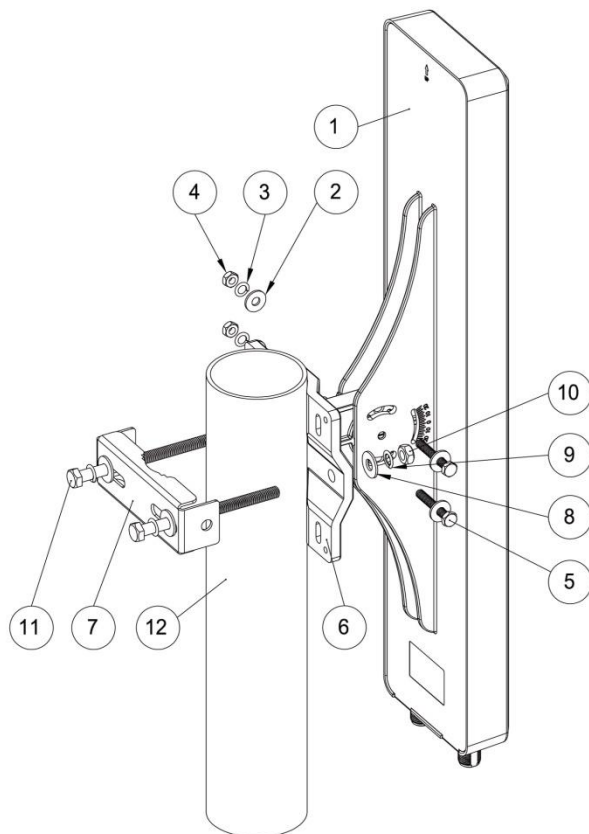

## 2.Wall Mounting

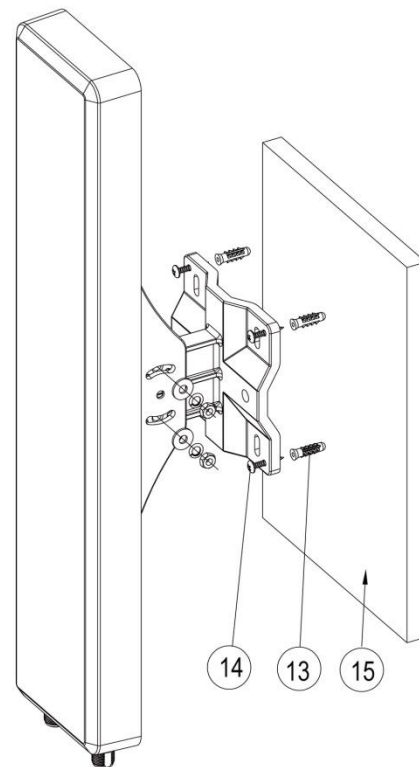

Note(備註):

1. Mounting recommended torque( 支架建議鎖緊扭力 ):80 Kgf.cm(7.84 N.m)
2. Mounting Max. torque( 支架最大鎖緊扭力 ):120 kgf.cm(11.76 N.m)